

## Chapter 9

# Anesthesia

### Introduction

Battlefield anesthesia primarily describes a state of balanced anesthesia using **adequate amounts of anesthetic agents** to minimize cardiovascular instability, amnesia, analgesia, and a quiescent surgical field in a technologically austere environment. Adapting anesthetic techniques to battlefield conditions requires flexibility and a reliance on fundamental clinical skills. While modern monitors provide a wealth of data, the stethoscope may be the only tool available in an austere environment. Thus, the value of crisp heart sounds and clear breath sounds when caring for an injured service member should not be underestimated. In addition, close collaboration and communication with the surgeon is essential.

### Airway

Many methods for securing a compromised airway exist, depending on the condition of the airway, the comorbid state of the patient, and the environment in which care is being rendered. When a definitive airway is required, it is generally best secured with direct laryngoscopy and an endotracheal tube (ETT), firmly secured in the trachea.

### Indications for a Definitive Airway

- Apnea/airway obstruction/hypercarbia.
- Impending airway obstruction: facial fractures, retropharyngeal hematoma, and inhalation injury.
- Excessive work of breathing.
- Shock (bp  $\leq$  80 mm Hg systolic).
- Glasgow Coma Scale (GCS)  $\leq$  8. (See Appendix 2.)
- Persistent hypoxia ( $\text{SaO}_2 < 90\%$ ).

### **Secondary Airway Compromise Can Result From**

- Failure to recognize the need for an airway.
- Inability to establish an airway.
- **Failure to recognize an incorrectly placed airway.**
- Displacement of a previously established airway.
- Failure to recognize the need for ventilation.

### **Induction of General Anesthesia**

#### **The Anesthesia Provider Must Evaluate the Patient for**

- Concurrent illness and current state of resuscitation.
- Airway — facial trauma, dentition, hyoid-to-mandibular symphysis length, extent of mouth opening.
- Cervical spine mobility (preexistent and trauma related).
- Additional difficult airway indicators.
  - Immobilization.
  - Children.
  - Short neck/receding mandible.
  - Prominent upper incisors.

### **Rapid Sequence Intubation Checklist**

- Equipment.
  - Laryngoscope, blades, and batteries (tested daily).
  - Suction, O<sub>2</sub> setup.
  - Endotracheal tubes and stylet.
  - Alternative tubes (oro, nasopharyngeal, LMA [laryngeal mask airway]).
  - IV access items.
  - Monitors — pulse ox, ECG, BP, end-tidal CO<sub>2</sub>.
  - Positive pressure ventilation (Ambu bag or anesthesia machine).
- Drugs.
  - Narcotics.
  - Muscle relaxants.
  - Anxiolytics and amnestics.
  - Induction agents and sedatives.
  - Inhalation agents.
- Narcotics.
  - **Fentanyl**, 2.0–2.5 µg/kg IV bolus, then titrate to effect.

- o **Morphine**, 5–10 mg IV bolus to load, then 2 mg q5min to effect.
- o **Dilaudid** (Hydromorphone), 1–2 mg IV to load, then 0.5 mg q5min to effect.
- Muscle relaxants.
  - o Depolarizing.
    - ◆ **Succinylcholine.**
      - ◇ 1.0–1.5 mg/kg.
      - ◇ Onset 30–60 sec.
      - ◇ Duration 5–10 min.
      - ◇ Can cause bradycardia, fasciculations, elevated intragastric pressure, elevated ICP, elevated intracranial pressure, potassium release (especially in “chronic” burn or immobile patients).
      - ◇ Potent trigger of malignant hyperthermia (MH).

**Succinylcholine should be NOT be used in patients with burns or crush injuries > 24 hours old or chronic neuromuscular disorders due to risk for hyperkalemia — rocuronium is the next best choice.**

- o Nondepolarizing.
  - ◆ **Vecuronium:** induction dose of 0.1 mg/kg with an onset of 2–3 minutes and duration of action of 30–40 minutes.
  - ◆ **Rocuronium:** induction dose of 0.6 mg/kg with an onset of 1.5–2.5 minutes and duration of action of 35–50 minutes. At 1.2 mg/kg onset similar to succinylcholine, but, unfortunately, a duration of action that can exceed 60–90 minutes.
  - ◆ **Pancuronium:** induction dose of 0.15 mg/kg with an onset of 3.5–6 minutes and duration of action of 70–120 minutes.
- Anxiolytics and amnestics.
  - o **Versed** (midazolam), 1–2 mg IV slowly (over 2 min).
  - o **Scopolamine**, 0.4 mg IV.
- Induction agents and sedatives (Table 9-1).

**Table 9-1. Induction Agents and Sedatives.**

Agent	Routine Dose *	Characteristics	Concerns
<b>Ketamine</b>	1.0–2.0 mg/kg IV	Dissociative anesthetic and amnestic. Sympathomimetic effects (useful in hypovolemia). Potent bronchodilator.	Varying degrees of purposeful skeletal movement despite intense analgesia and amnesia.
	4.0–8.0 mg/kg IM	Onset within 30–60 sec. Emergence delirium avoided with concomitant benzodiazepine use.	Increased salivation, consider an antisialagogue.
<b>Barbiturates (eg, thiopental)</b>	3–5 mg/kg	Onset within 30–60 seconds.	May cause profound hypotension in hypovolemic shock patients.
<b>Propofol</b>	1.5–2.5 mg/kg	Mixed in lipid, strict sterility must be ensured. Rapid onset and rapidly metabolized. Onset within 30–60 seconds.	Contraindicated in acute hypovolemic shock patients.
<b>Etomidate</b>	0.2–0.4 mg/kg	Onset within 30–60 seconds. Duration 3–10 min. Minimal cardiac effects. Minimal effects on peripheral and pulmonary circulation. Maintains cerebral perfusion.	May cause clonus.

\* All induction agents can be used for induction of severely injured patients if reduced dosages are used (eg,  $1/2$  of the lower recommended dose). However, the recommended choice for hypovolemic patients would be Ketamine > etomidate >> thiopental > propofol.

**Rapid Sequence Intubation (RSI) 7 steps\***

1. Preoxygenate with 100% oxygen by mask.
2. Consider fentanyl—titrate to maintain adequate blood pressure and effect (2.0–2.5  $\mu\text{g}/\text{kg}$ ).
3. Cricoid pressure—Sellick maneuver until endotracheal tube (ETT) placement is confirmed and balloon is inflated.
4. Induction agent: etomidate 0.1–0.4 mg/kg IV push.
5. Muscle relaxant: succinylcholine 1.0–1.5 mg/kg IV push.
6. Laryngoscopy and orotracheal intubation.
7. Verify tube placement.

\*For children, see page 33.6.

- Endotracheal intubation.
  - Orotracheal.
    - ◆ Direct laryngoscopy 60–90 seconds after administration of induction agents and neuromuscular blockade.
    - ◆ First attempt is the best chance for success, but have a backup plan:
      - ◇ Optimize positioning of patient and anesthesia provider.
      - ◇ Have adjuncts readily available (stylet, smaller diameter tubes, alternative laryngoscope blades, suction, laryngeal mask airway, lighted stylet).
  - Nasotracheal should generally not be performed.
  - Other considerations.
    - ◆ Maintain cricoid pressure until balloon inflated and tube position is confirmed.
    - ◆ Hypertension can be managed with short-acting medications such as beta blockers (labetalol, esmolol) or sodium nitroprusside.
    - ◆ May treat induction-related (transient) hypotension initially with small dose of ephedrine (5–10mg) or Neosynephrine (50  $\mu\text{g}$ ), but if hypotension persists after induction agents are metabolized, use fluids to treat the persistent hypovolemia. The anesthesiologist must convey this situation to the surgeon, as the need to control bleeding becomes urgent.

- ◆ A sensitive airway can be topically anesthetized with lidocaine 1.5 mg/kg 1–2 minutes before laryngoscopy.
- Verify ETT placement.
  - Auscultate the lungs.
  - Measure the end-tidal CO<sub>2</sub>.
  - Ensure that the SaO<sub>2</sub> remains high.
  - Palpate cuff of ETT in sternal notch.
  - Place the chemical CO<sub>2</sub> sensors in the airway circuit.

**Verification of tube placement is VITAL. Any difficulty with oxygenation/ventilation following RSI should prompt evaluation for immediate reintubation.**

### **The Difficult Airway (see Chapter 5, Airway and Breathing)**

Initially provide airway management with jaw-thrust, facemask oxygenation, and assess the situation. Failed RSI may be due to inadequate time for induction agents to work; inadequate time for muscle relaxation to occur; anatomically difficult airway; or obstruction due to secretions, blood, trauma, or foreign material.

- Resume oxygenation; consider placing a temporary oral airway.
- Reposition patient and anesthesia provider.
- Call for help.
- Consider alternatives to RSI.
  - Awake intubation.
  - Laryngeal mask airway.
  - Regional anesthesia or local anesthesia.
  - Surgical airway.

### **Maintenance of General Anesthesia**

#### **General Anesthesia Is Maintained After Intubation With**

- Oxygen. Titrate to maintain SaO<sub>2</sub> > 92%.
- Ventilation.
  - Tidal volume (TV) 10–15 cc/kg.
  - Respiratory rate (RR) 6–10/min.
  - PEEP (positive end-expiratory pressure) if desired at 5 cm H<sub>2</sub>O, titrate as necessary.
- Minimal alveolar concentration (MAC).
  - 0.3–0.5 MAC: awareness abolished although 50% of patients respond to verbal commands.

- o 1 MAC: 50% of patients do not move to surgical stimulus.
- o 1.2 MAC: 95% of patients do not move to surgical stimulus.
- o Common inhalation agent MACs:
  - ◆ Halothane: 0.75%.
  - ◆ Sevoflurane: 1.8%.
  - ◆ Isoflurane: 1.17%.
  - ◆ Enflurane: 1.63%.
  - ◆ Nitrous Oxide ( $N_2O$ ) = 104%.
  - ◆ Additive effects (eg, 60%  $N_2O$  mixed with 0.8% sevoflurane yields 1 MAC).
- Total intravenous anesthesia (TIVA).
  - o Mix midazolam 5 mg, vecuronium 10 mg, ketamine 200 mg in 50 cc normal saline (NS) and infuse at 0.5 cc/kg/h (stop 10–15 minutes before end of surgery).
  - o Mix 50–100  $\mu$ g of ketamine with 500 mg of propofol (50 cc of 10% propofol) and administer at 50–100  $\mu$ g/kg/min (21–42 mL/h for a 70 kg patient).
- Balanced anesthesia (titration of drugs and gases) combine:
  - o 0.4 MAC.
  - o Versed 1–2 mg/h.
  - o Ketamine 2–4 mg/kg/h.

### Conclusion of General Anesthesia

- If the patient is to **remain intubated**, anesthetics may be terminated but sedatives and muscle relaxants are maintained.
- If the patient is to be **extubated**, ventilation is decreased to allow the patient to spontaneously breathe.
  - o Anesthetic agents are stopped 5 minutes before conclusion of surgery.
  - o Glycopyrrolate (Robinul) (0.01–0.02 mg/kg IV over 3–5 minutes) to decrease parasympathetic stimulation and secretions. This can be administered at the same time or before neostigmine.
  - o Muscle relaxation reversal with neostigmine (0.04–0.08 mg/kg IV over 3–5 minutes, can be mixed in same syringe as glycopyrrolate).
- Extubation criteria include reversal of muscle relaxation, spontaneous ventilation, response to commands, eye

opening, and head lifting for 5 seconds. **When in doubt, keep the patient intubated.**

- Amnestic therapy with midazolam and analgesic therapy with a narcotic is appropriate in small amounts so as not to eliminate the spontaneous respiratory drive.

### **Regional Anesthesia**

Regional anesthesia (RA) is a “field friendly” anesthetic requiring minimal logistical support while providing quality anesthesia and analgesia on the battlefield. Advantages of RA on the modern battlefield are listed below.

- Excellent operating conditions.
- Profound perioperative analgesia.
- Stable hemodynamics.
- Limb specific anesthesia.
- Reduced need for other anesthetics.
- Improved postoperative alertness.
- Minimal side effects.
- Rapid recovery from anesthesia.
- Simple, easily transported equipment needed.

Recent conflicts have revealed that the majority of casualties will have superficial wounds or wounds of the extremities. RA is well suited for the management of these injuries either as an adjunct to general anesthesia or as the primary anesthetic. The use of basic RA blocks is encouraged when time and resources are available.

- Superficial cervical plexus block.
- Axillary brachial plexus block.
- IV regional anesthesia.
- Wrist block.
- Digital nerve block.
- Intercostobrachial nerve block.
- Saphenous nerve block.
- Ankle block.
- Spinal anesthesia.
- Lumbar epidural anesthesia.
- Combined spinal-epidural anesthesia.
- Femoral nerve block.



Prior training in basic block techniques is implied, and use of a nerve stimulator, when appropriate, is encouraged to enhance block success. More advanced blocks and continuous peripheral nerve blocks are typically not available until the patient arrives at a combat support hospital (CSH) or higher level health care facility where personnel trained in these techniques are available. A long-acting local anesthetic such as 0.5% ropivacaine is used for most single-injection peripheral nerve blocks. Peripheral nerve blocks can often be used to treat pain (without the respiratory depression of narcotics) while patients are waiting for surgery.

- **Neuraxial anesthesia.**
  - Subarachnoid block (SAB).
  - Epidural block.

**When the patient's physical condition allows the use of spinal or epidural anesthesia those techniques are encouraged.** The sympathectomy that results is often poorly tolerated in a trauma patient and this must be factored into any decision to use those techniques. Peripheral nerve blocks do not have this limitation.

- **Local anesthesia.**

When local anesthesia would suffice, such as in certain wound debridements and wound closures, it should be the technique of choice.

### **Field Anesthesia Equipment**

There are two anesthesia apparatuses currently fielded in the forward surgical environment: (1) the draw-over vaporizer and (2) a conventional portable ventilator machine. A schematic of the draw-over system is shown in Figure 9-1.

- **Draw-over vaporizer.**
  - Currently fielded model: Ohmeda Portable Anesthesia Complete (PAC).
  - Demand type system (unlike the plenum systems in hospital-based ORs).
    - ◆ When the patient does not initiate a breath or the self-inflating bag is not squeezed, there is **no flow of gas**. No demand equals no flow.
  - Temperature-compensated flow-over in-line vaporizer.

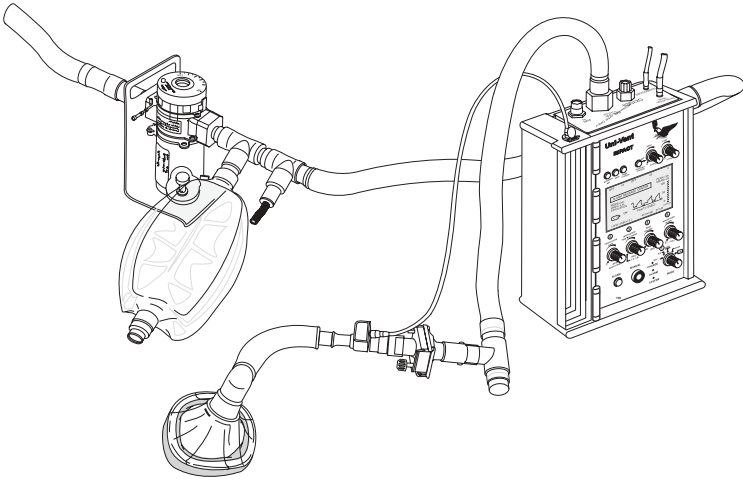

Fig. 9-1. Draw-over apparatus in combination with the ventilator.

- o Optimal oxygen conservation requires a larger reservoir (oxygen economizer tube [OET]) than is described in the operator's manual — a 3.5 ft OET optimizes  $FiO_2$ .
- o May be used with spontaneous or controlled ventilations.
- o Bolted-on performance chart outlines dial positions for some commonly used anesthetics (eg, halothane, isoflurane, enflurane, and ether). **Ether is highly flammable; use extreme care.**

### Ohmeda UPAC Draw-Over Apparatus in Combination With the Impact Uni-Vent Eagle 754 Portable Ventilator:

- Currently, there is no mechanical ventilator specifically designed for use with the UPAC draw-over apparatus, but use with various portable ventilators has been studied in both the draw-over and push-over configuration.
  - o Adding the ventilator frees the anesthesia provider's hands while providing more uniform ventilation and more consistent concentrations of the inhalational anesthetic agent.

- o The **draw-over** configuration places the ventilator distal to the vaporizer, entraining ambient air and vapor across the vaporizer in the same manner as the spontaneously breathing patient. Do not attach a compressed source of air to the Impact Uni-Vent Eagle 754 in this configuration because the Uni-Vent Eagle 754 will preferentially deliver the compressed gases and will not entrain air/anesthetic gases from the UPAC draw-over.
- o The **push-over** configuration places the ventilator proximal to the vaporizer, effectively pushing entrained ambient air across the vaporizer and then to the patient.
- The Impact Uni-Vent Eagle 754 portable ventilator (Figure 9-1) is not part of the UPAC apparatus but is standard equipment for the US military. It has been used in combination with the Ohmeda UPAC Draw-Over Apparatus.
  - o The air-entrainment (side intake) port is used to create the draw-over/ventilator combination.
    - ◆ The side intake port of the ventilator contains a nonreturn valve preventing back pressure on the vaporizer which could result in erratic and inconsistent anesthetic agent concentrations.
  - o The patient air-outlet port on the ventilator also contains a nonreturn valve, preventing back flow into the ventilator from the patient side.
  - o Scavenging of waste gases can be accomplished by attaching corrugated anesthesia tubing to either the outlet port of the Ambu-E valve (induction circuit) or the exhalation port of the ventilator tubing (ventilator circuit) venting to the outside atmosphere.
  - o The following items are added to the circuit to improve this UPAC/Impact Uni-Vent Eagle 754 ventilator combination:
    - ◆ Small and large circuit adapters to aid in attachment of various pieces.
    - ◆ PALL Heat and Moisture Exchange Filter to conserve heat and limit patient contact with the circuit.
    - ◆ Accordion circuit extender to move the weight of the circuit away from the patient connection.
    - ◆ O<sub>2</sub> extension tubing to attach supplemental O<sub>2</sub>.

- o Two separate circuits should be constructed for use with the UPACTM/Uni-Vent Eagle 754 combination: one for induction and spontaneous ventilation and the second for controlled ventilation using the portable ventilator.
  - ◆ This process can be complicated because switching circuit components requires several disconnections and reconnections, creating the potential for error. (Practice.)
- **Conventional plenum anesthesia machine.**
  - o Currently fielded models: Drager Narkomed and Magellan 2000.
  - o Compact version of standard OR machines, with comparable capabilities.